

WHITE SHARK 205

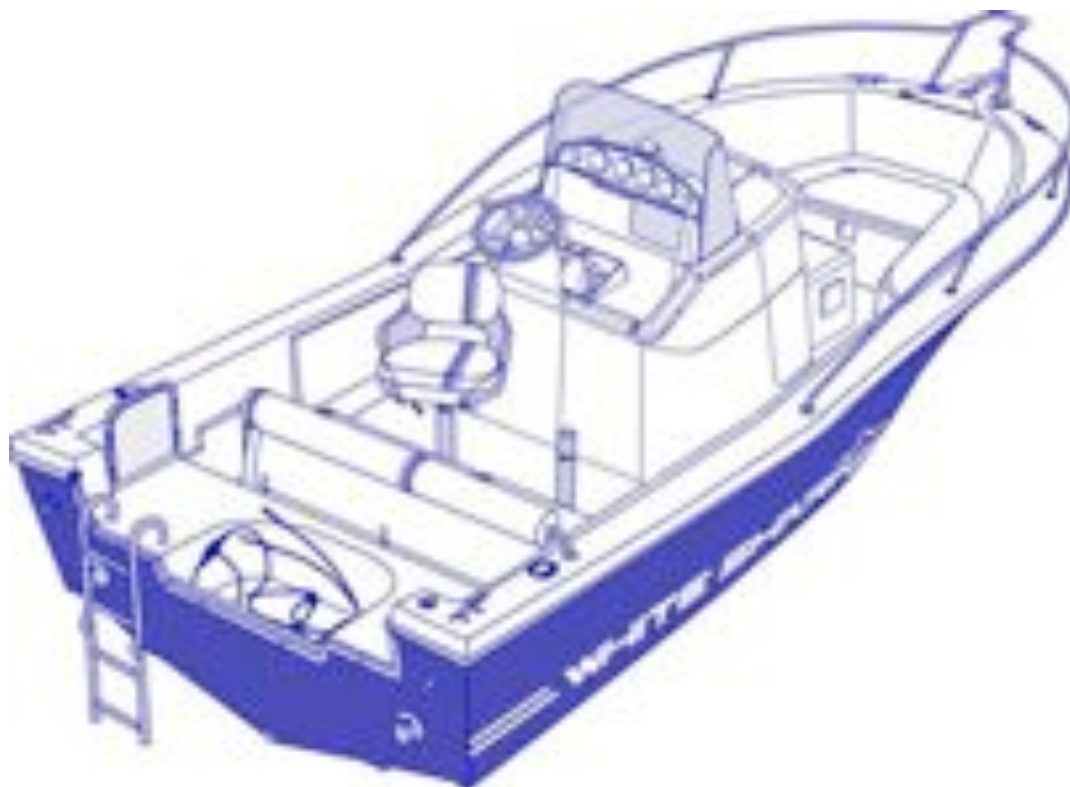

SPECIFICATIONS

L.O.A. / Maximum length (L_{\max})	: 6.10 m
Hull length (L_H)	: 5.96 m
Maximum beam (B_{\max})	: 2.40 m
Builder's weight without engine	: 920 kilos approx. (950 kg / 'i' version)
Draught	: 0.35 m approx. – engine up
Fuel tank	: 130 litres
Maximum engine weight for 'i' version	: 240 kilos
Recommended power	: 150 HP (112 kW)
Maximum power	: 150 HP (112 kW)
Number of passengers	: 7
Design & construction category (E.U.)	: C
Tonnage	: 2.97 t

Dimensions (L_{\max} , L_H , B_{\max}) indicated above are set according to ISO 8666 standards



KELT SAS – 55, rue Alain Gerbault – 56037 VANNES CEDEX – FRANCE
Tel. + 33 (0) 2 97 54 17 89 - Fax + 33 (0) 2 97 47 33 38
Web site : www.kelt.fr - e.mail : contact@kelt.fr

FEATURES / EQUIPMENT

- Bow / lifting eye
- Bow pulpit with anchor roller
- Self bailing anchor locker with eye-bolt
- 2 bow stainless steel cleats
- 2 stern stainless steel cleats
- Stainless steel bow rail
- PVC rubbing strake with stainless steel strip
- 2 gunnel-mounted rod holders
- 2 stern / lifting eyes
- Removable swimming ladder
- Automatic bilge pump
- Battery box
- Battery switch
- Navigation lights
- Fuel filler
- Hydraulic steering
- Fresh water deck shower

HELM AREA

- Ergonomic console
- Plexiglass windscreen / windshield
- Stainless steel console grab rail
- Stainless steel windscreen grab rail
- Stainless steel steering wheel with knob
- Trim tilt indicator
- Compass
- Lockable glove compartment
- Space for electronic equipment
- Courtesy light
- Waterproof switch panel
- Gauges and engine controls are supplied with the engine and vary according to the engine brand
- Maintenance briefcase

UNSINKABLE VERSION (205 i)

Specifications as per the standard version except for the under gunnel rod racks located in a foamed area to ensure that the boat is unsinkable

In a constant move to improve products, KELT reserves the right to modify or change construction specifications at all times without prior notice and without any backdated implication on boats already built. This document cannot be considered as contractual.

WS 205 – 01/12/2005

CONSOLE

- Large console with 1.30 m headroom with space for chemical toilet

COCKPIT

- Large self bailing cockpit
- high freeboard for better safety
- Pilot and co-pilot swivel & sliding seats with leaning post position
- Ice box
- Under gunnel rod racks
- Centre console with access door
- Aft swim platform with access swivel door
- Aft bench seat with backrest
- forward seat

STORAGE SPACE

- Anchor locker
- Large console with plenty of storage
- Large locker under aft seat
- Large forward locker

OPTIONS

- Bimini top
- Bi-cruiser bimini
- Chemical toilet
- Console cover
- Forward sundeck cushions with table
- Hull colour
- Leaning post
- Leather steering wheel
- Stainless steel T-Top
- Tackle box
- Water ski tow mast
- Wood steering wheel
- CLUB Version (hull colour, bimini top, console cover)

Your distributor :

TECNICA MARKETSAILING S.L
C/LLORENS Y BARBA 9-11 , LOCAL 10
08025-BARCELONA – ESPAÑA
TEL 93-456-37-60 FAX 93-456-39-84
comercial@tecnicaTMS.com
www.tecnicaTMS.com